

---

# FAG Rolling Bearings For Rail Vehicles

Complete Delivery Program

---

FAG Industrial Bearings AG

Publ. No. WL 07 150 EA



---

**FAG Rolling Bearings For Rail Vehicles**  
Complete Delivery Program

**Publ. No. WL 07 150 EA**

**FAG Industrial Bearings AG**

Railway & Transport

Postfach 1260 · D-97419 Schweinfurt

Telefon +49-97 21-91 39 98 · Telefax +49-97 21-91 37 88

E-mail: [proeschel\\_e@fag.de](mailto:proeschel_e@fag.de)

[www.fag.de](http://www.fag.de)

Cylindrical roller bearings for axle boxes: for long-distance trains . . . . .	4
for suburban rail vehicles . . . . .	6
TAROL tapered roller bearing units . . . . .	8
TAROL units: to AAR standard . . . . .	10
in metric dimensions . . . . .	11
Axle boxes with spherical roller bearings . . . . .	12
Axle box housings and adapters . . . . .	13
Polyamide cages . . . . .	14
Greases Arcanol for rail vehicle bearings . . . . .	15
Gearbox bearings . . . . .	16
Bearing types and designs for rail vehicle transmissions . . . . .	18
Drive bearings . . . . .	20
Bearings for traction motors . . . . .	22
Tools for mounting and dismounting . . . . .	24
Research, development, service . . . . .	26
Rail vehicles with FAG rolling bearings . . . . .	28

# FAG cylindrical roller bearings for axle boxes for long-distance trains

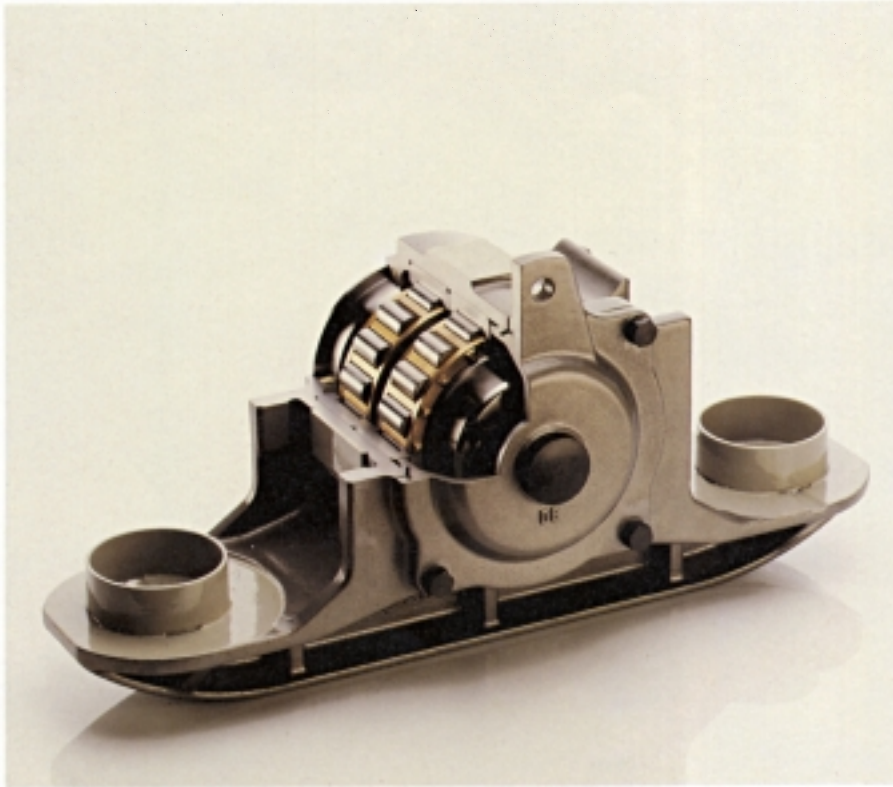

◁ ... for freight cars

▽ ... for passenger cars

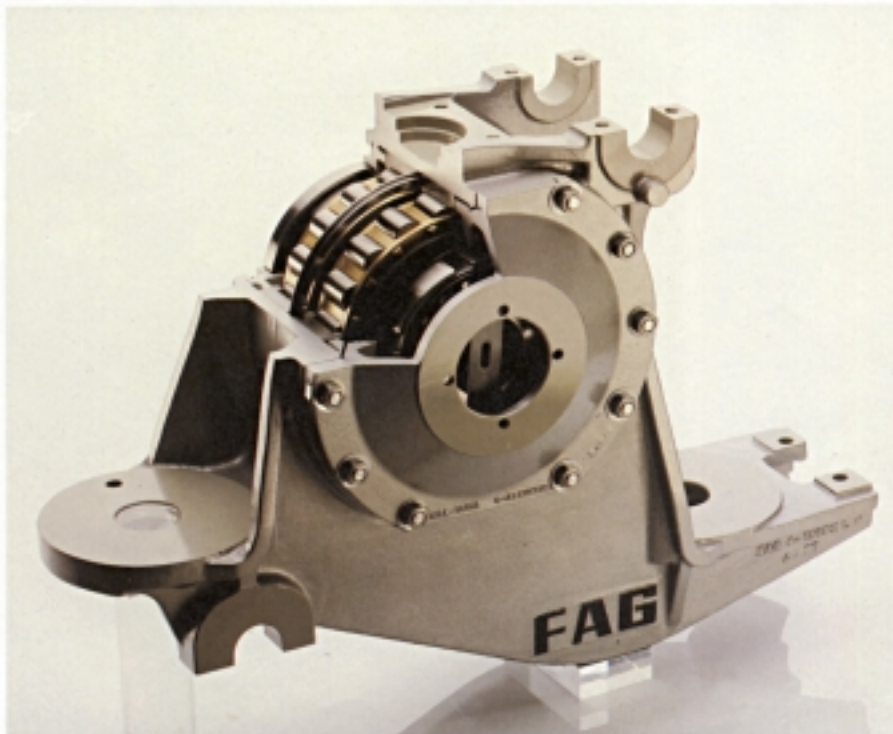

◁ ... for locomotives

▽ ... for freight cars





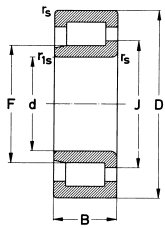

WJ

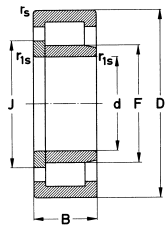

WJP..P

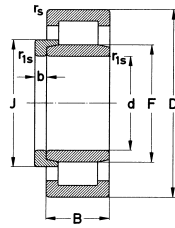

WU..W

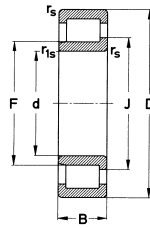

NJ

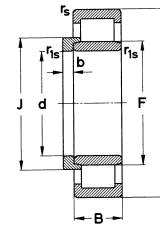

NU..HJ

Shaft	Dimensions								Load rating dyn. C	Number	Weight ≈		
	d	D	B	r <sub>s</sub> min	r <sub>1s</sub> min	b	J	F				FAG	kg
	mm										kN		
<b>100</b>	100	200	67	4	4		132	121.5	390	WJ100x200M	10.3		
	100	200	67	4	4		132	121.5	390	WJP100x200P.M	10.3		
	100	200	67	4	4	13	132	121.5	390	WU100x200W.M	10.78		
<b>105</b>	105	215	73	4	4		140.5	129.5	455	WJ105x215M	13.3		
	105	215	73	4	4		140.5	129.5	455	WJP105x215P.M	13.3		
	105	215	73	4	4	13	140.5	129.5	455	WU105x215W.M	13.76		
<b>110</b>	110	215	73	4	4		147	135.5	455	WJ110x215M1	12.5		
	110	215	73	4	4		147	135.5	455	WJP110x215P.M1	12.5		
	110	215	73	4	4	13	147	135.5	455	WU110x215W.M1	12.5		
<b>120</b>	120	240	80	4	4		161	150	560	WJ120x240M1 *)**)	17.9		
	120	240	80	4	4		161	150	560	WJP120x240P.M1 *)**)	17.9		
	120	240	80	4	4	14	161	150	560	WU120x240W.M1	18.63		
<b>130</b>	130	240	80	4	4		167.5	157	540	WJ130x240M1 *)**)	16.8		
	130	240	80	4	4		167.5	157	540	WJP130x240P.M1 *)**)	16.8		
	130	250	80	3	3		171	158	570	566751TVP	15.8		
	130	250	80	3	3		171	158	570	566752TVP	15.8		
	130	260	86	4/10*	4		178	164	695	WJ130x260M1	22.6		
	130	260	86	4	4		178	164	695	WJP130x260P.M1	22.6		
	130	260	86	4	4	14	178	164	695	WU130x260W.M1	23.53		
<b>150</b>	150	270	73	3	3		193.7	182	655	NJ2230E.M1.C4.F2	19.2		
	150	270	73	3	3	12	193.7	182	655	NU 2230E.M1.C4.F2 (with angle ring HJ2230E.F2)	19.2		
	150	300	102	5/10*	5		203	188	865	WJ150x300M1	35.8		
	150	300	102	5	5		203	188	865	WJP150x300P.M1	35.8		

\* first value for outer ring, second value for inner ring  
 \*) Bearing according to UIC standard  
 \*\*) also with TVP cage (glass-fibre reinforced polyamide)  
 FAG also supplies current insulated cylindrical roller bearings in DIN ISO dimensions.

# FAG cylindrical roller bearings for axle boxes for suburban rail vehicles

◁ ... for urban trains

▽ ... for trams

◁ ... suburban trains

▽ ... for underground trains

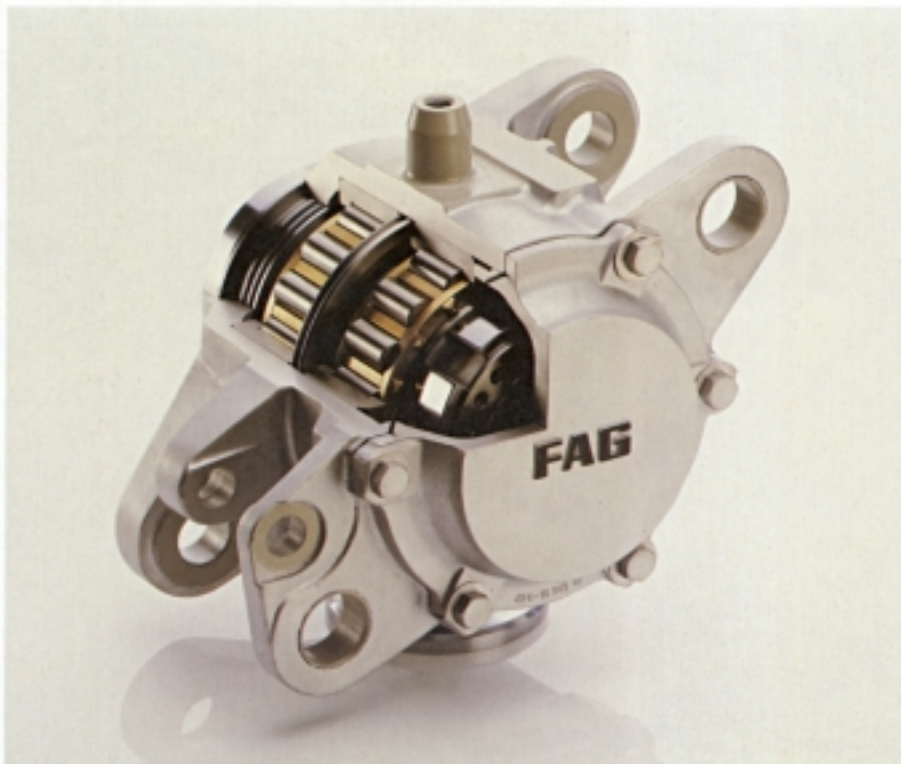
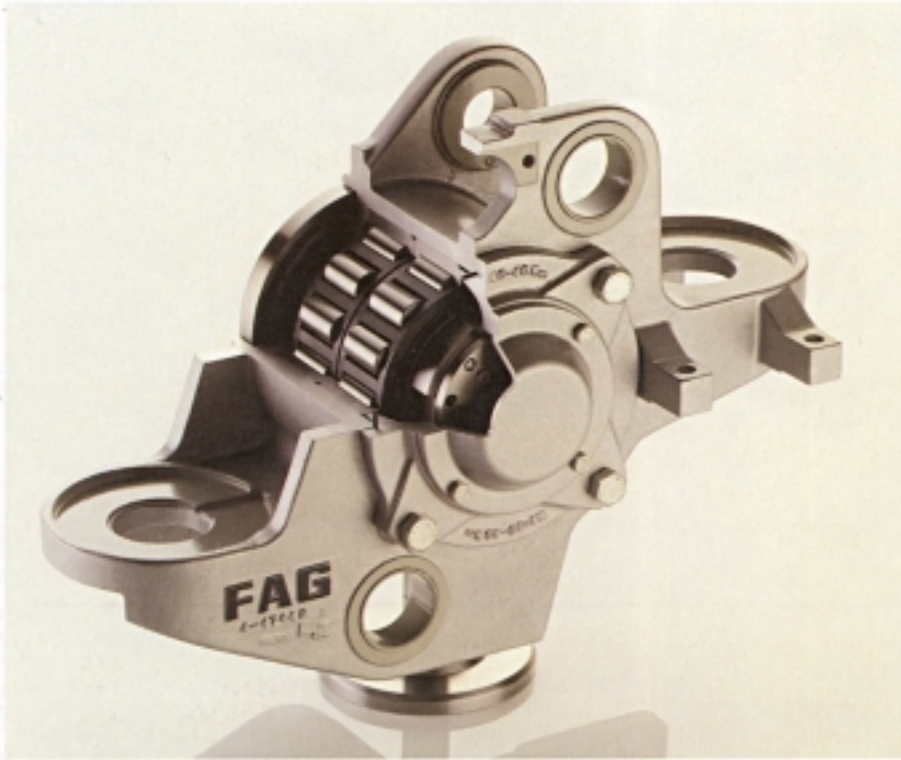

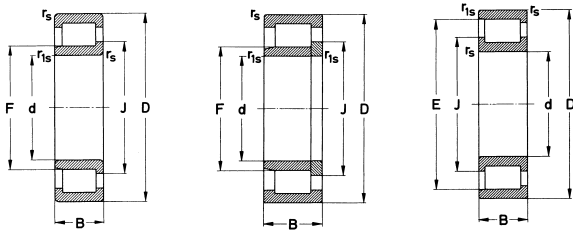

NJ

NJP

NF

Shaft	Dimensions								Load rating dyn. C	Number	Weight ≈		
	d	D	B	r <sub>s</sub> min	r <sub>1s</sub> min	J	F	E				FAG	kg
	mm										kN		
<b>80</b>	80	140	42	2	2	101.5	95.3	—	186	574316	2.37		
	80	140	42	2	2	101.5	95.3	—	186	574317	2.48		
	80	170	58	2.1	2.1	110.6	101	—	355	NJ2316E.TVP2.C3.F2.H25	5.89		
	80	170	58	2.1	2.1	110.6	101	—	355	NJP2316ED.TVP2.C3.F2.H25	5.89		
<b>90</b>	90	160	48	2	2	114.25	107	—	240	574332	3.63		
	90	160	48	2	2	114.25	107	—	240	574333	3.76		
	90	160	52.4	2	2	114.25	107	—	240	WJ90x160TVP	3.84		
	90	160	52.4	2	2	114.25	107	—	240	WJP90x160P.TVP	3.96		
	90	190	64	3	3	124	113.5	—	430	NJ2318E.TVP2.C3.F2.H25	8.01		
	90	190	64	3	3	124	113.5	—	430	NJP2318ED.TVP2.C3.F2.H25	8.01		
<b>100</b>	100	180	55	2.1	2.1	127.3	119	—	335	574334	5.4		
	100	180	55	2.1	2.1	127.3	119	—	335	574335	5.59		
	100	180	60.3	2.1	2.1	127.3	119	—	335	WJ100x180TVP	5.73		
	100	180	60.3	2.1	2.1	127.3	119	—	335	WJP100x180P.TVP	5.9		
	100	180	46	2.1	2.1	127.3	—	163	335	NF2220E.M1.C4.F2	4.77		
	100	215	73	3	3	139.6	127.5	—	570	NJ2320E.TVP2.C4.F2.H25	12		
	100	215	73	3	3	139.6	127.5	—	570	NJP2320ED.TVP2.C4.F2.H25	12		
<b>110</b>	110	200	53	2.1	2.1	141.6	—	180.5	380	NF2222E.M1.C4.F2	6.68		
<b>120</b>	120	215	58	2.1	2.1	153.5	—	195.5	450	NF2224E.M1.C4.F2	8.29		

FAG also supplies current insulated cylindrical roller bearings in DIN ISO dimensions.

# TAROL tapered roller bearing units of FAG

Advantages: ready-to-mount, only one mounting step necessary, sealed, lubricated, with adjusted axial clearance

Double cup, cone with roller assembly and spacer are also available as single components.

▽ Single parts of a TAROL unit with lamellar rings

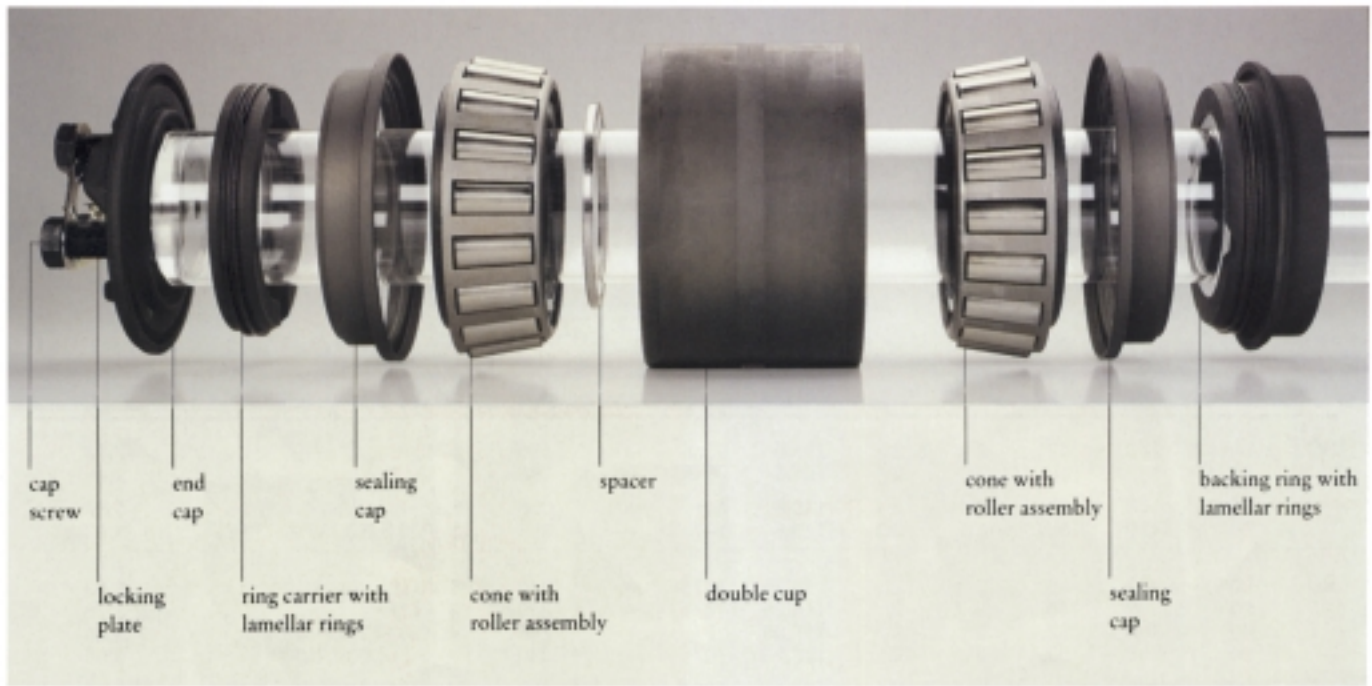

Type for the UIC (Union Internationale des Chemins de Fer, Paris) in metric dimensions.

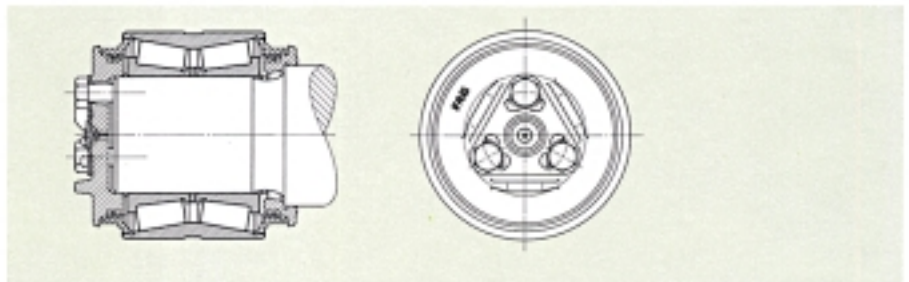

Type designed according to AAR specification (Association of American Railroads) in inch dimensions. Exchangeability is guaranteed.

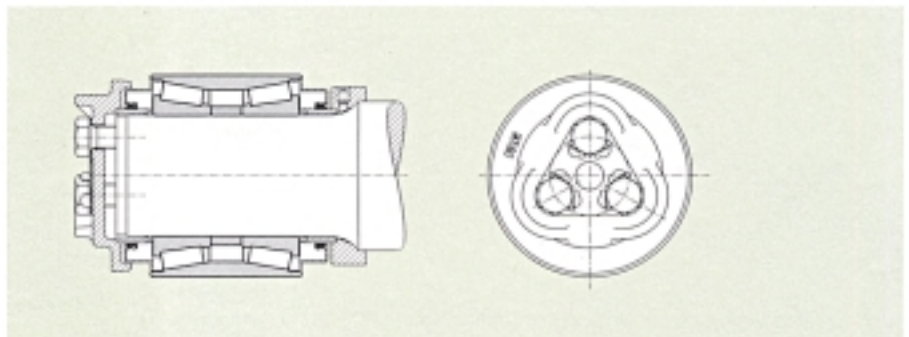



... for passenger train cars



TAROL units can be adapted to each case of application. This is a design with an outside diameter of 154 mm, for a low-floor wagon.

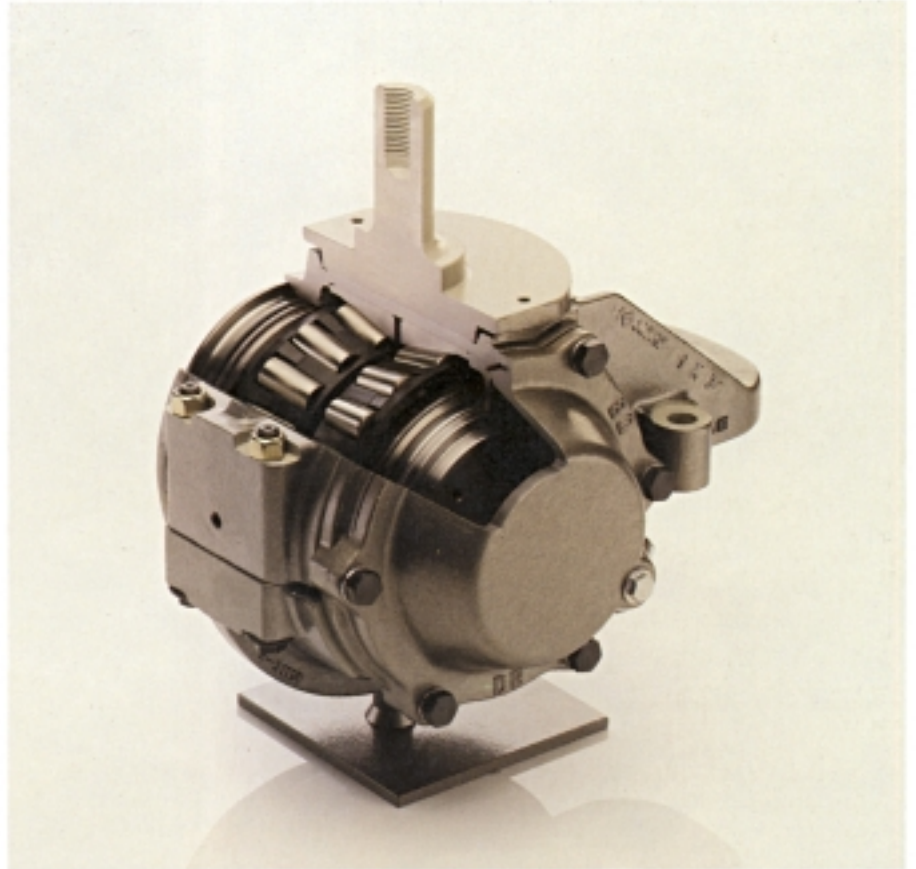
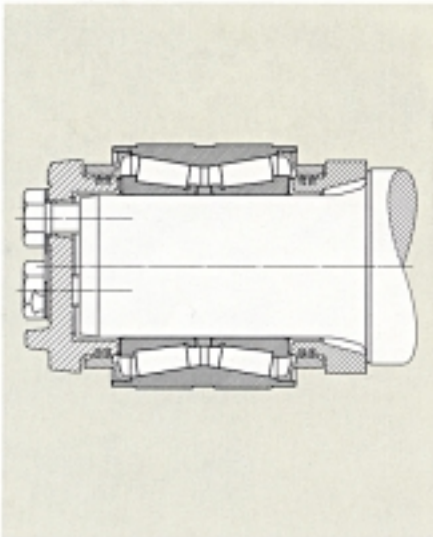

... for high-speed trains



# TAROL units

to AAR standard

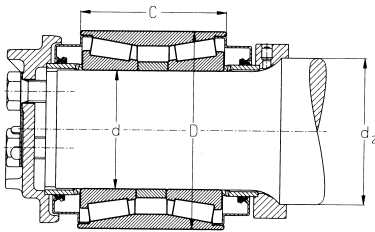

Class	Dimension			Bearing d	D	C	Load rating dyn C	Max. load shaft	Weight ≈ TAROL unit
	Shaft d max inch mm	d min	d <sub>2</sub>						
<b>B 4 1/4 x 8</b>	4.004	4.003	5	4	6.5	4.5	101100	24000	40.0
	101.702	101.676	127	101.6	165.1	114.3	450	107	18.1
<b>C 5 x 9</b>	4.6915	4.6905	5 7/8	4.6875	7.6875	5.625	139300	33500	67.0
	119.164	119.139	149.225	119.063	195.263	142.875	620	149	30.4
<b>D 5 1/2 x 10</b>	5.1915	5.1905	6 3/8	5.187	8.1875	6	155100	42000	60.4
	131.864	131.839	161.925	131.75	207.963	152.4	690	187	27.4
<b>E 6 x 11</b>	5.6915	5.6905	7.030/7.032	5.687	8.6875	6.437	161800	52500	74.3
	144.564	144.539	178.562/178.613	144.45	220.663	163.5	720	234	33.7
<b>F 6 1/2 x 12</b>	6.1915	6.1905	7.530/7.532	6.187	9.9375	7.25	224700	63000	119.9
	157.264	157.239	191.262/191.313	157.15	252.413	184.15	1000	280	50.7
<b>G 7 x 12</b>	7.004	7.003	8.000/8.002	6.9995	10.875	7.312	251700	76000	137.8
	177.902	177.876	203.200/203.251	177.787	276.225	185.725	1120	338	62.5

**Class**      **Order designation<sup>1)</sup>**

B 4 1/4 x 8	TAROL.4.1/4x8.U.E34*.H46C
C 5 x 9	TAROL.5x9.U.E34*.H46C
D 5 1/2 x 10	TAROL.5.1/2x10.U.E34*.H46C
E 6 x 11	TAROL.6x11.U.E34*.H46C
F 6 1/2 x 12	TAROL.6.1/2x12.U.E34*.H46C
G 7 x 12	TAROL.7x12.U.E34*.H46C

<sup>1)</sup> The suffixes mean:

U	complete unit
E34*	packing
H46C	end cap (NFL) without relubrication possibility with collar, backing ring without collar
* is replaced by A = individual packing D = pallet packing (US standard)	

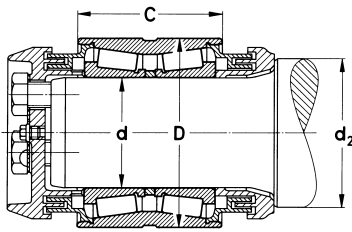

90-Design

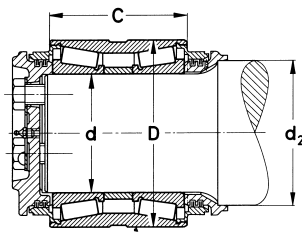

SK-Design

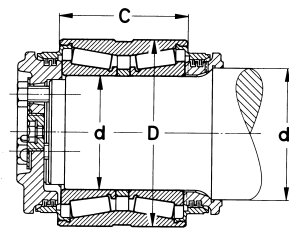

MK-Design

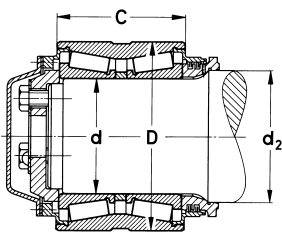

MK..C-Design

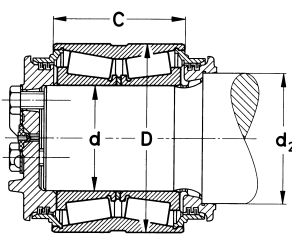

UIC-Design

Size	Dimension						Load rating dyn C	Weight ≈ TAROL kg	Order designation <sup>1)</sup>  FAG
	Shaft d max mm	d min	d <sub>2</sub>	Bearing d	D	C			
<b>90</b>	90.035	90.013	120	89.99	154.1	115	425	14.9	517918
<b>90 SK</b>	90.035	90.013	110	89.99	154.1	115	425	11.9	528735
<b>100 SK</b>	100.059	100.037	126	99.98	165	114.3	450	13.9	517874
<b>MK 120</b>	120.059	120.037	138.162	119.982	195	131.4	620	21.5	517827
<b>MK 120C</b>	120.059	120.037	138.162	119.982	195	131.4	620	19	517905
<b>MK 130</b>	130.068	130.043	150.174	129.992	210	132	690	25.5	517828
<b>MK 130C</b>	130.068	130.043	150.174	129.992	210	132	690	22	517906
<b>UIC 130C</b>	130.068	130.043	160.174	130	230	160	1020	34	549784
<b>MK 140</b>	140.068	140.043	160.174	139.992	220	140	720	30	517830
<b>MK 140C</b>	140.068	140.043	160.174	139.992	220	140	720	27	517907
<b>MK 150</b>	150.068	150.043	170.186	149.992	250	160	1000	46	517831
<b>MK 150C</b>	150.068	150.043	170.186	149.992	250	160	1000	40	517908

<sup>1)</sup> Please add the packaging specification to the order designation: E34A for individually packed bearings; E34B for pallet-packed bearings.  
Example: 517828.E34B

Backing ring and end cap can be adapted to an existing axle journal.  
The bearings can be relubricated via a plug or a lubrication nipple in the end cap or at the double cup between the roller rows.

## FAG axle boxes with spherical roller bearings

### FAG axle boxes with spherical roller bearings

FAG supplies axle boxes with spherical

roller bearings for freight cars, locomotives, and other rail vehicles. FAG produces spherical roller bearings in all popular series with machined brass

cages. Production and inspection is done according to the specifications of the railway company in question.

- ▽ Freight car axle bearing according to UIC specifications. The FAG 502472A spherical roller bearing with  $d = 130$  mm,  $D = 220$  mm,  $B = 73$  mm and  $r_s = 3$  mm has a load rating of  $C = 585$  kN under dynamic load and a weight of 12 kg.

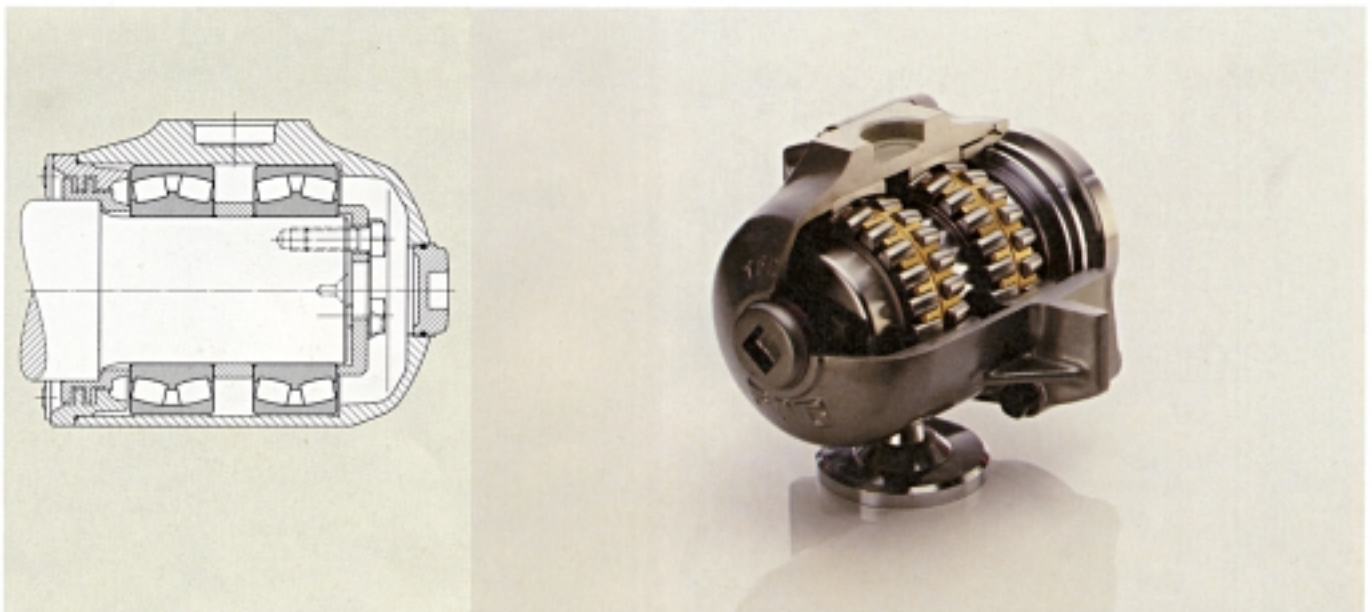

- ▽ Axle box bearings for a locomotive of the Yugoslavian Railways

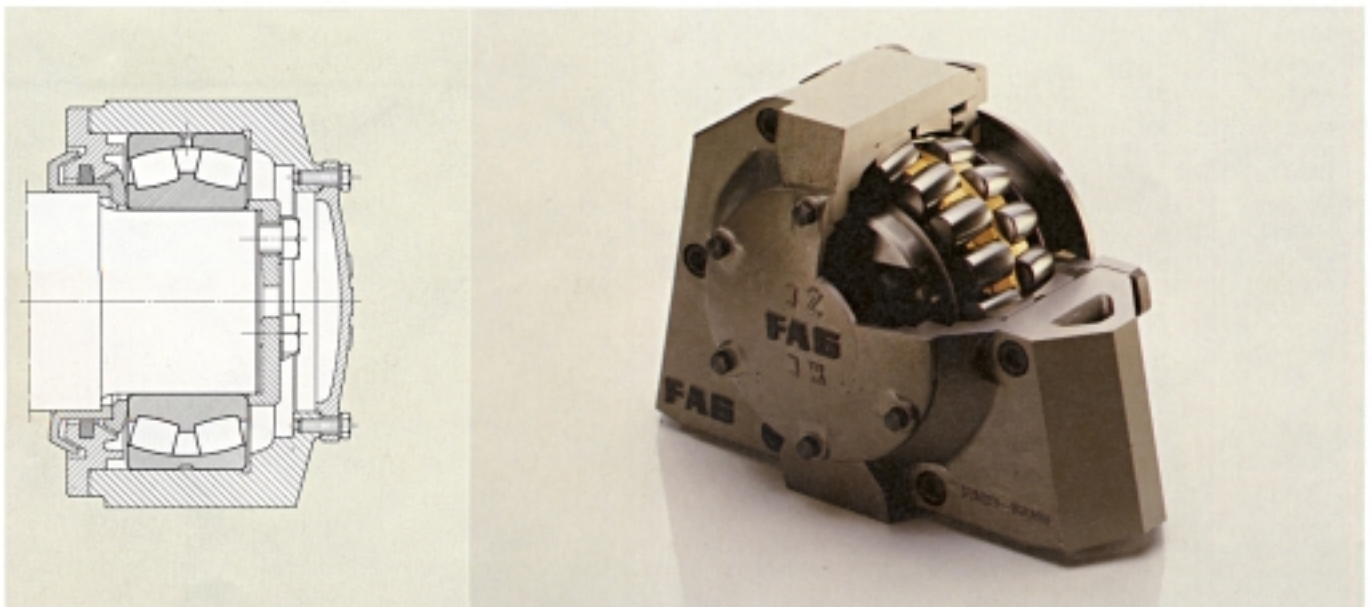



FAG axle box housings and adapters

made of cast steel, spheroidal cast iron, and light metal

▽ ... for the ICE middle coach

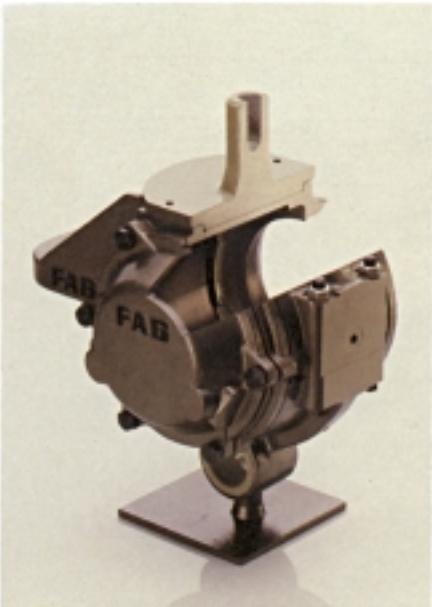

▽ ... for freight cars



▽ ... for suburban rail cars



▽ Special adapter



▽ Special adapter

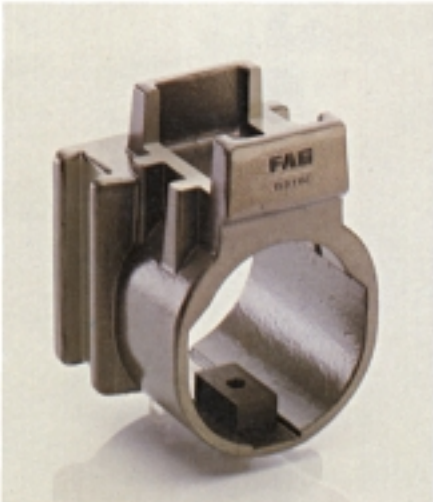

▽ Narrow adapter



## FAG polyamide cages

### FAG polyamide cages

FAG produces cylindrical roller bearings

and tapered roller bearing units also with cages of glass-fibre reinforced polyamide.

The polyamide cages are also available as single components.

▽ ... for cylindrical roller bearings

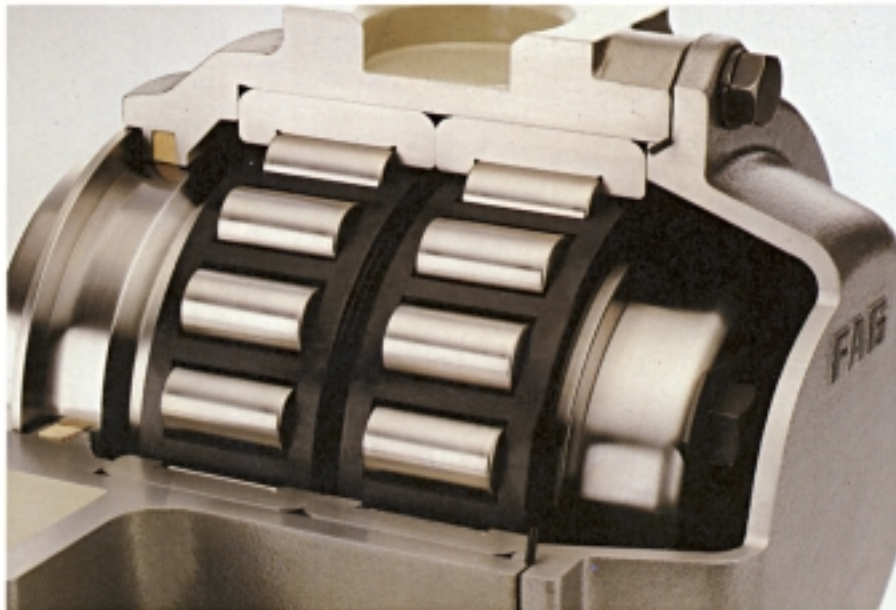

▽ ... for tapered roller bearings

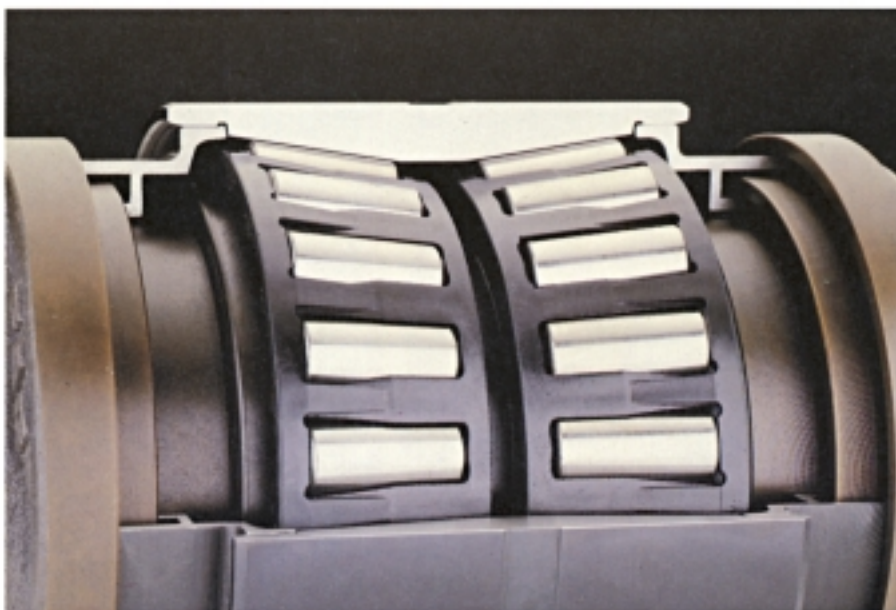

# FAG greases Arcanol for rail vehicle bearings

Designation	Application	Operating temperature	Penetration according to NLGI classes	Base oil type	Viscosity				Thickening agent	Drop point
					at 20 °C	40 °C	50 °C	100 °C		
Arcanol		°C			mm <sup>2</sup> /s				°C	
Lithium soap base grease										
L71	1, 2, 3 (Universal grease)	-30 ... + 140	3	MIN	74			8	Li	185
L101	1, 2, 3 (Universal grease)	-30 ... + 140	3	MIN	96				Li	185
L62	1, 2, 3 (Universal grease USA)	-30 ... + 120	3	MIN			70	11	Li	
L99	1 (Suburban rail)	-20 ... + 130	3	MIN	470	119		10.3	Li	190
L121	1, 2, 3 (Universal grease)	-25 ... + 130	3	MIN	430	116		11.7	Li	200
L45	1 (mainly USA)	-30 ... + 120	1	MIN		159			Li	
Lithium soap base grease EP										
L156	1 (high speeds)	-35 ... + 130	2...3	MIN	40		26		Li	185
L37	1 (mainly TAROL)	-25 ... + 140	2	MIN	700	180		16	Li	196
L42	1 (mainly TAROL)	-25 ... + 130	2	MIN		150			Li	185
L147	1 (mainly TAROL)	-20 ... + 120	2	MIN			130	16	Li	
L135	1 (high speeds)	-40 ... + 140	2	MIN	400	85		9.3	Li	180
Lithium complex soap base grease										
L40	3	-30 ... + 165	3	MIN		113		12	Li-compl.	> 250
Calcium soap base grease										
L73	1	-30 ... + 120	2	MIN		67		8	Ca	135



# FAG gearbox bearings

## FAG gearbox bearings

Cylindrical roller bearings, four-point bearings, angular contact ball bearings,

deep groove ball bearings, tapered roller bearings and spherical roller bearings are mounted in mechanic and hydraulic transmissions for shaft guidance.

The wide variety of FAG gearbox bearings for shaft diameters between 10 and 400 millimeters is presented on pages 18 and 19.

Bull gear shaft with two tapered roller bearings



Voith turbo-transmission T211r for self-propelled coaches, overhead line examination cars, snow plough wagons and similar rail vehicles. Transmission input power 216 kW (280 HP). Transmission weight 680 kg. The shafts of the hydrodynamic power transmission are supported by cylindrical roller bearings and deep groove ball bearings.

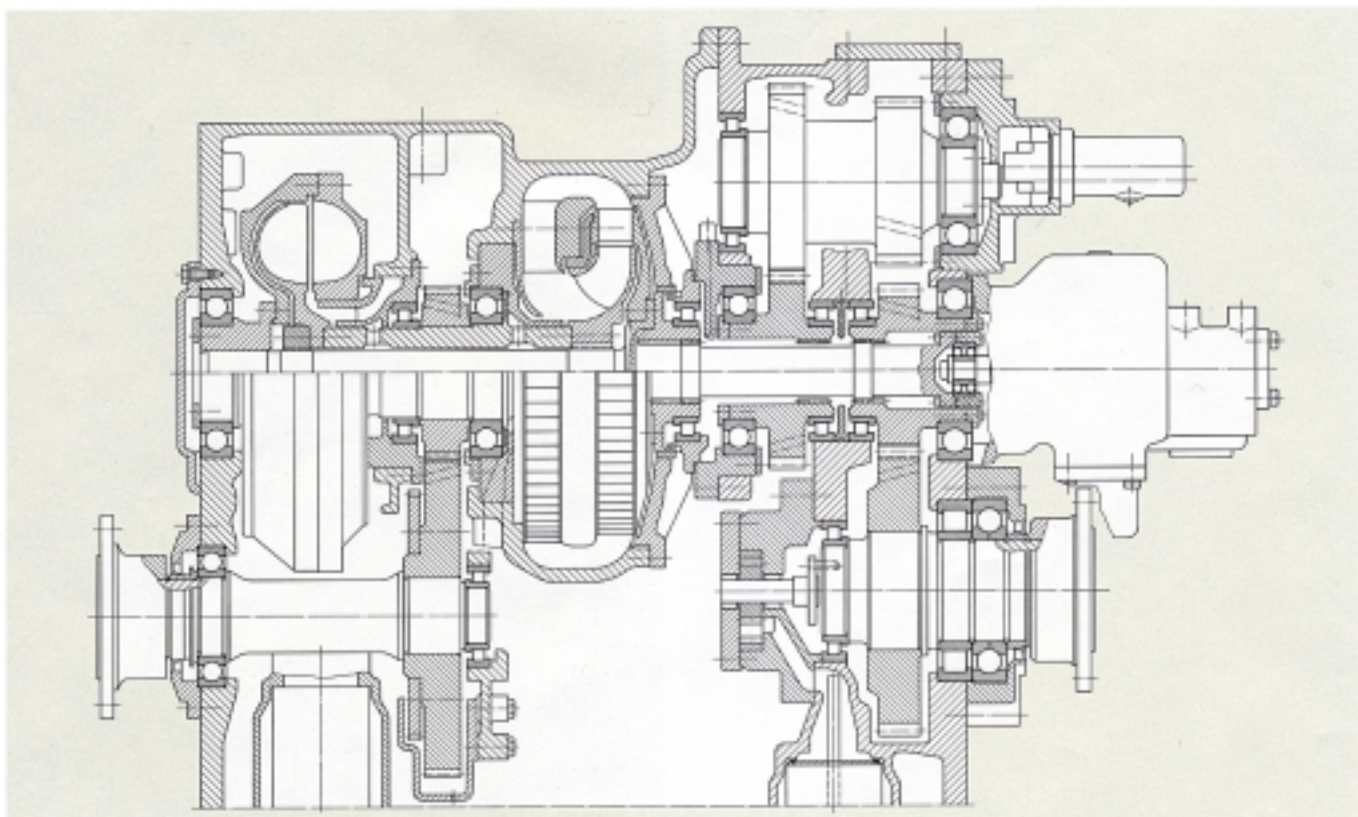
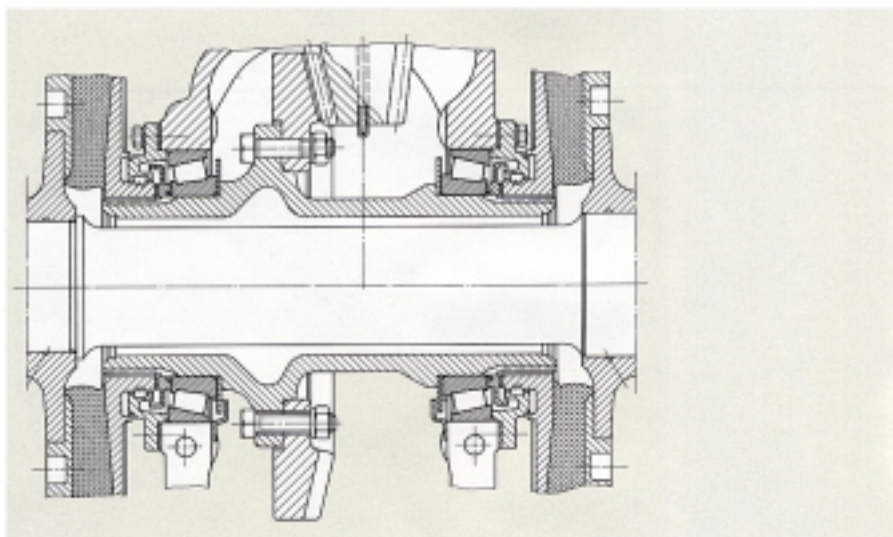



▷ Pinion shaft with two cylindrical roller bearings and one four point bearing or two tapered roller bearings

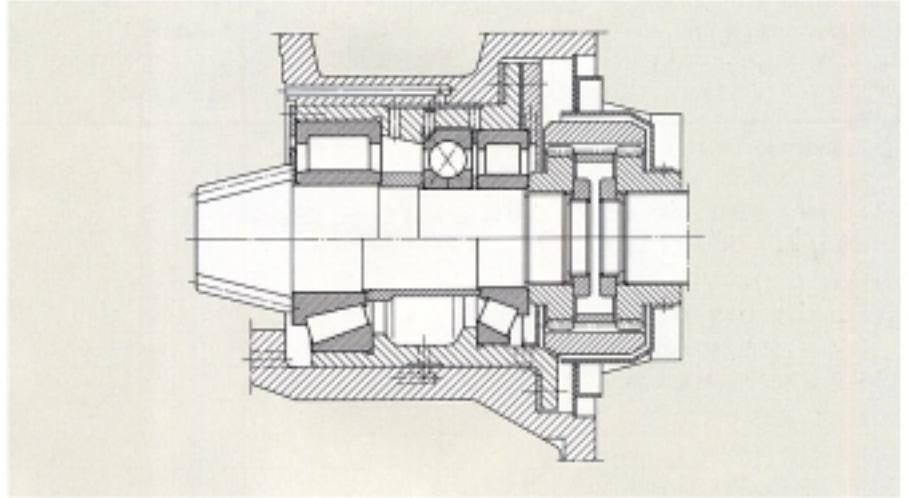

▷ Pinion shaft with tapered roller bearings (O-arrangement) and one cylindrical roller bearing or with two cylindrical roller bearings and one double row angular contact ball bearing.

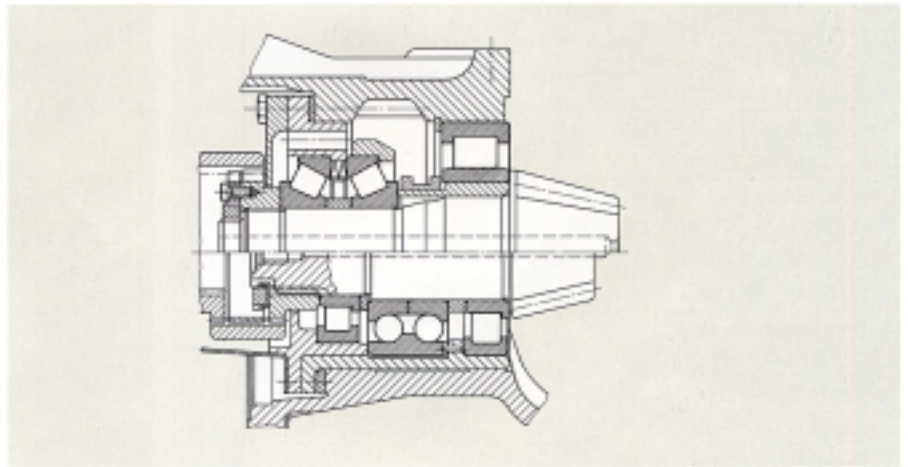

▷ Gear shaft with two cylindrical roller bearings and one four point bearing

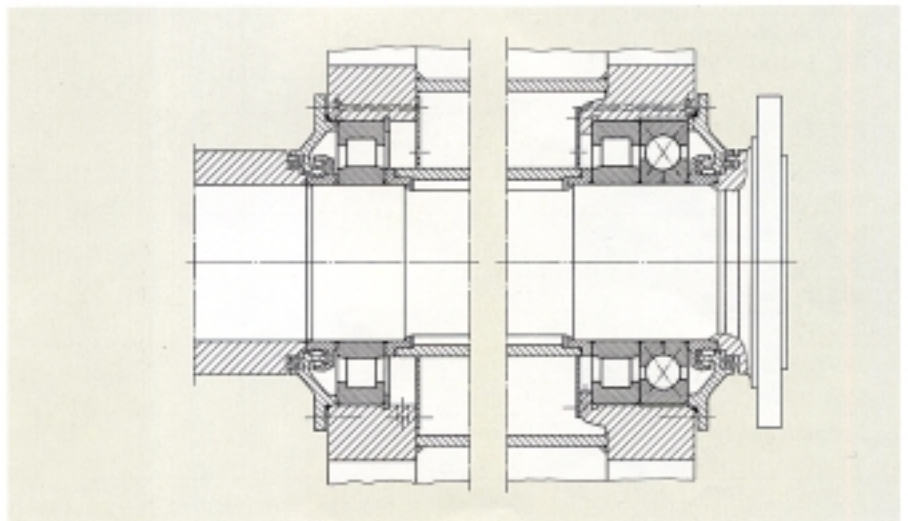



# FAG drive bearings

## FAG drive bearings

FAG bearings can be used for all types of railway drive systems.

Suspension bearings with two tapered roller bearings or with two cylindrical roller bearings

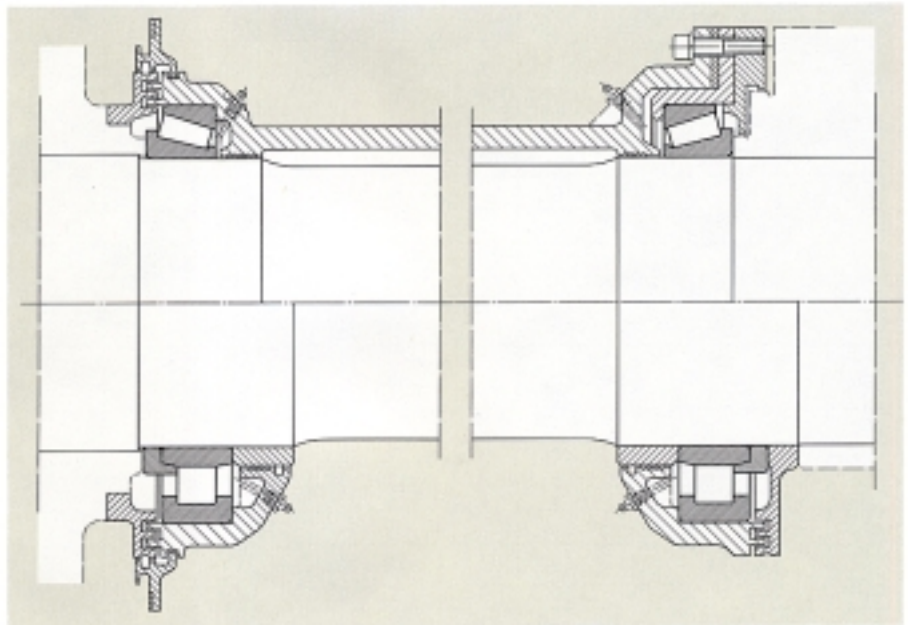

In the standard bogie of electric rail cars:  
Cylindrical roller bearings (wheelset, engine), deep groove ball bearings (engine), spherical roller bearings (suspension bearing arrangement)

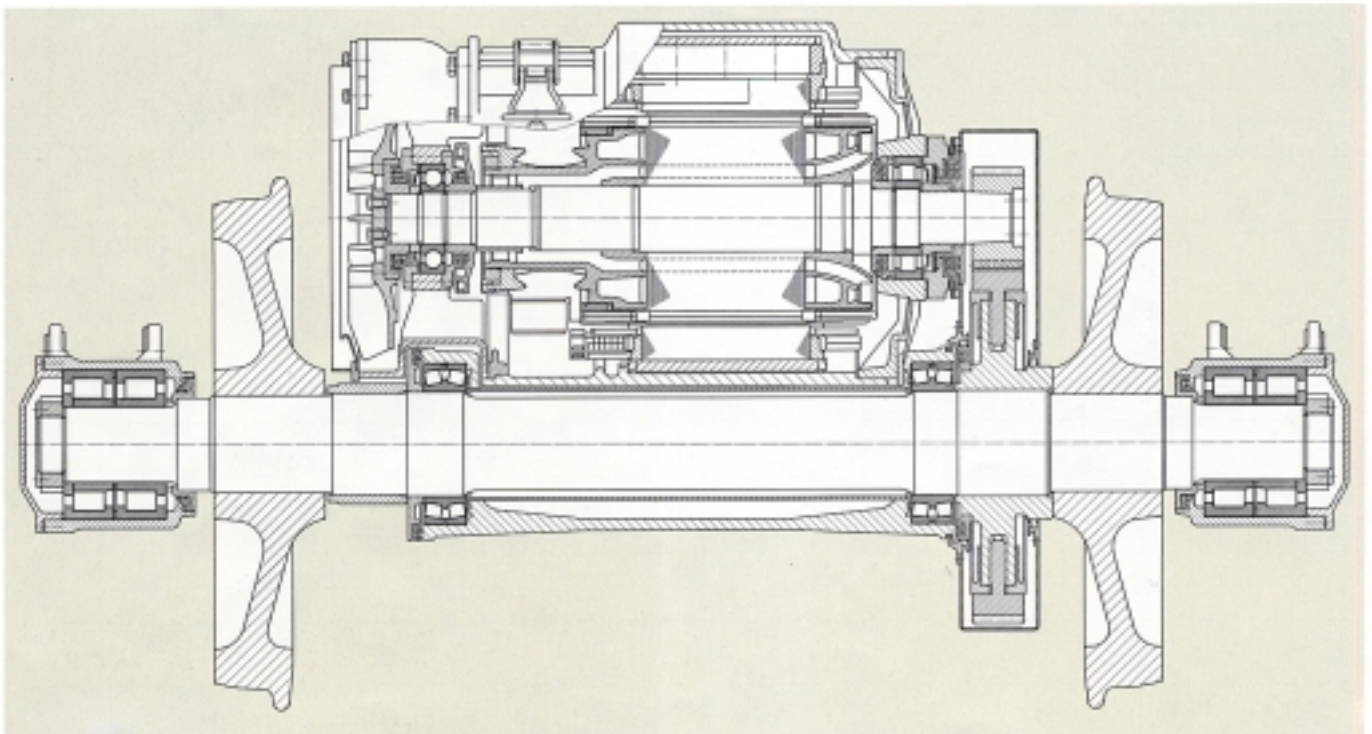



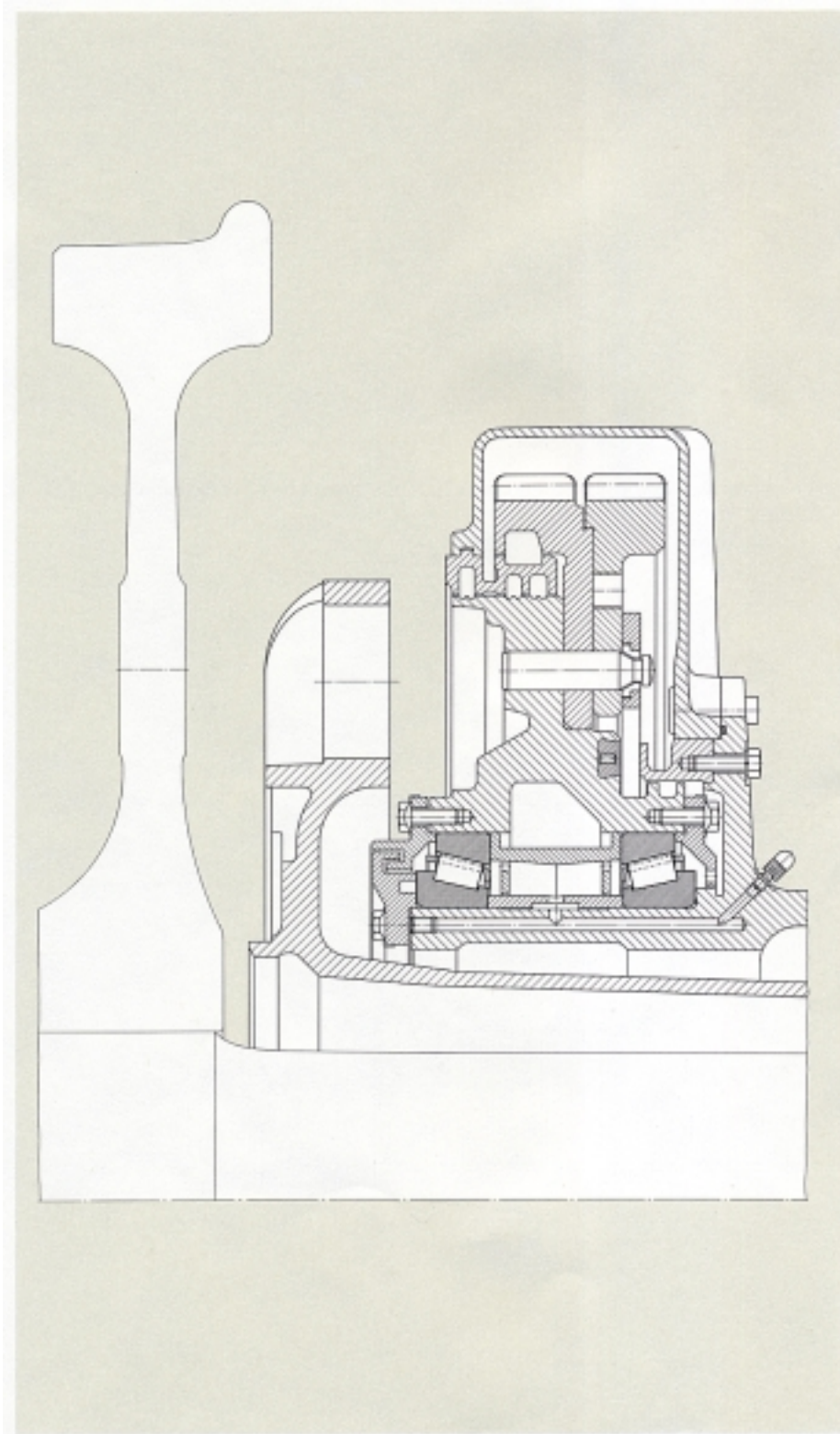

Large wheel bearings in the drive of the DB locomotive 120  
Bearing unit of two tapered roller bearings,  
matched with spacers  
◁

The delivery program of FAG includes other products for many different kind of vehicles on rails, support and guide rollers and wheels, bearings in auxiliary units.



# FAG bearings for traction motors

## FAG bearings for traction motors

The bearings of traction motors are usually supported as follows:

Pinion end

- Cylindrical roller bearings, design NU (narrow series)

Commutator end

- Cylindrical roller bearings NJ with angle ring HJ or
- cylindrical roller bearings NUP or
- deep groove ball bearings

▽ Design example of standard locomotive traction motor. The universal locomotives E120 of the German Federal Railways are used for freight and passenger train operation at speeds of up to 200 km/h.

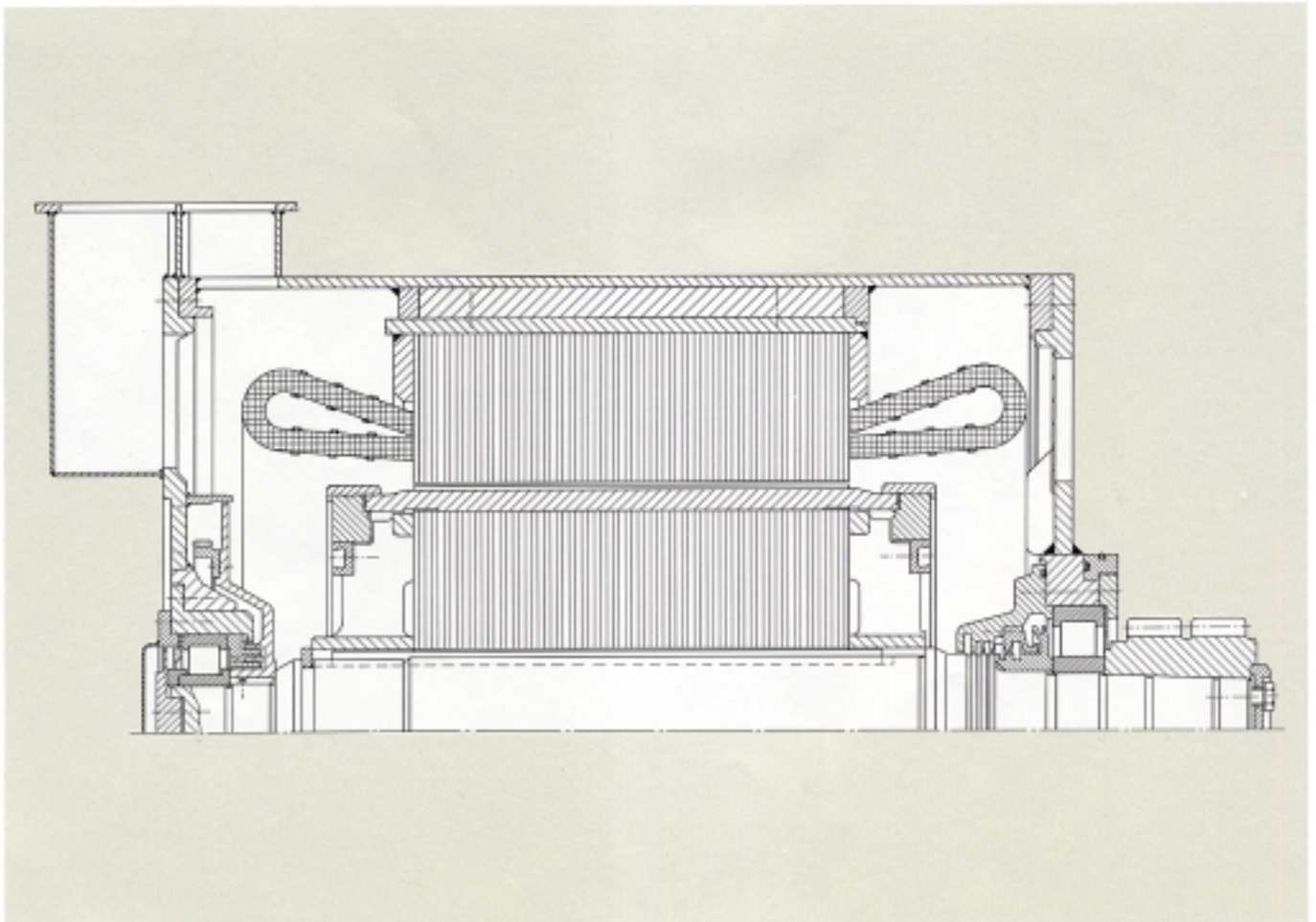

▽ Current bearing sizes for European manufacturers' traction motors

Bore d mm	NU10	NU NJ NUP2	NU NJ NUP3	63 ..
30				
35				
40			○	
45			○	
50			○	
55			○	
60		○	○	○
65		○	○	○
70		○	○	○
75		○	○	○
80		○	○	○
85		○	○	○
90		○	○	○
95		○	○	○
100		○	○	○
110		○	○	○
120		○	○	○
130	○	○	○	○
140	○	○	○	○
150	○	○	○	○
160	○	○	○	○
170	○	○	○	○
180	○	○	○	○
190	○	○	○	○
200	○	○	○	○
220	○			
240	○			

▽ Bearings in US traction motors

Manu- facturer	Motor number	Pinion end Number	Commutator end
<b>FAG</b>			
General- Electric	GE-716	558826D	NJ318E.M1.F1.795124 HJ318E.F1
	GE-720	558826D	NJ318E.M1.F1.795124 HJ318E.F1
	GE-723	NU322E.M1.F1.795124	NJ317E.M1.F1.795124 HJ317E.F1
	GE-726	558830C	558320C
	GE-730	558830C	558320C
	GE-731	558826D	NJ318E.M1.F1.795124 HJ318E.F1
	GE-733	NU412M1.F1.795124	6212ZR
	GE-741	NU412M1.F1.795124	6212ZR
	GE-746	558830C	558320C
	GE-748	NU418M1.F1.795124	6313.C3
	GE-752	558830C	558320C
	GE-754	558826D	NJ318E.M1.F1.795124 HJ318E.F1
	GE-755	558830C	558320C
	GE-756	NU322E.M1.F1.795124	6316.C3
	GE-761	558826D	6318.C4
GE-1204	6313ZR.C3	6309ZR.C3	
GE-1213	6313ZR.C3	6310ZR.C3	
GE-1240	NU314E.M1.F1.795124	6312.C3	
HM-833	NU322E.M1.F1.795124	NJ317E.M1.F1.795124 HJ317E.F1	
HM-838	NU320E.M1.F1.795124	NJ316E.M1.F1.795124 HJ316E.F1	
HM-846	NU316E.M1.F1.795124	NJ312E.M1.F1.795124 HJ312E.F1	
Westing- house	WE-362-D	558826D	NJ318E.M1.F1.795124 HJ318E.F1
	WE-362-DZ	NU328E.M1.F1.795124	NJ322E.M1.F1.795124 HJ322E.F1
	WE-370	NU328E.M1.F1.795124	NJ318E.M1.F1.795124 HJ318E.F1
	WE-370-DEZ	NU328E.M1.F1.795124	NJ318E.M1.F1.795124 HJ318E.F1
	WE-561	NU324E.M1.F1.795124	NJ314E.M1.F1.795124 HJ314E.F1
	WE-563	NU322E.M1.F1.795124	NJ312E.M1.F1.795124 HJ312E.F1
	WE-776	NU328E.M1.F1.795124	NJ318E.M1.F1.795124 HJ318E.F1
	WE-970	NU322E.M1.F1.795124	NJ314E.M1.F1.795124 HJ314E.F1
	WE-974	NU322E.M1.F1.795124	NJ312E.M1.F1.795124 HJ312E.F1
	Electro- Motive	D7 - 77	558540D

Suffix:

E	= reinforced design	
F1	= bearing for traction motors according to DIN 43283	
M1	= machined brass cage with integral crosspiece rivets, roller-riding	Order examples:
M	= machined brass cage with steel rivets, roller-riding	Locating bearing NJ318E.M1.F1.795124 HJ318E.F1
C3/C4	= Clearance larger than normal	
P6	= Tolerance class P6	
J20A	= Current insulated	Floating bearing
795124	= bearing for US traction motors	NU328E.M1.F1.795124

## FAG tools for mounting and dismounting

FAG tools, equipment, devices for mounting and dismounting rolling bearings, for maintenance of carriage stock

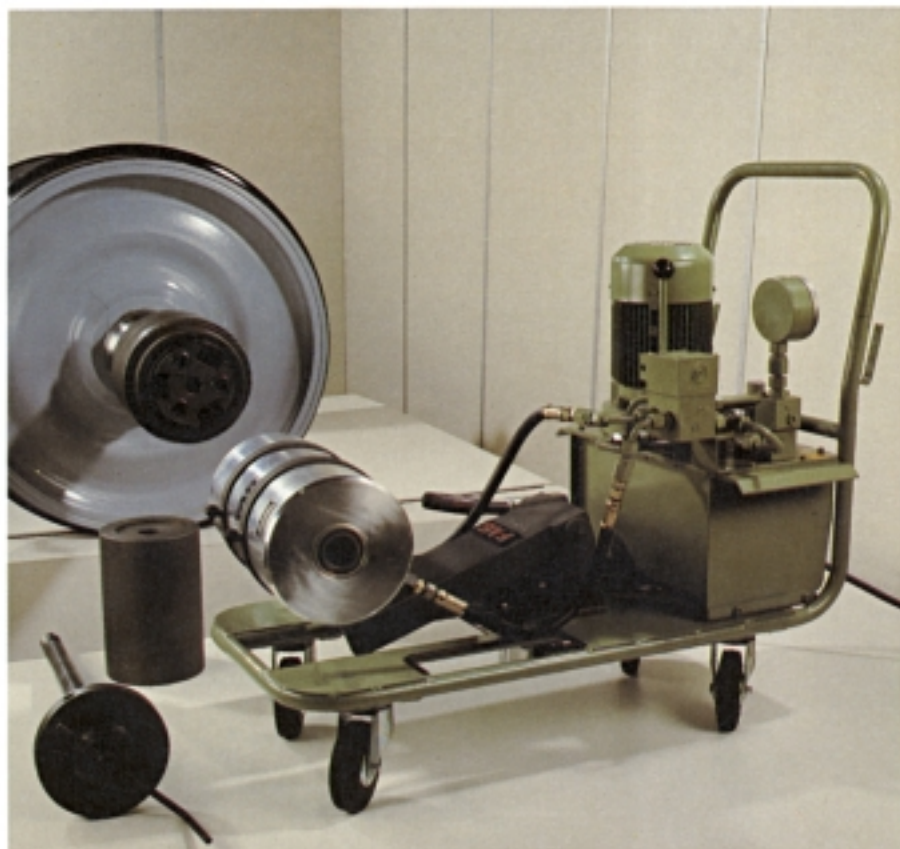

Motor press for TAROL mounting.  
Devices for mounting and dismounting  
◀

▽ Mounting equipment with transformer

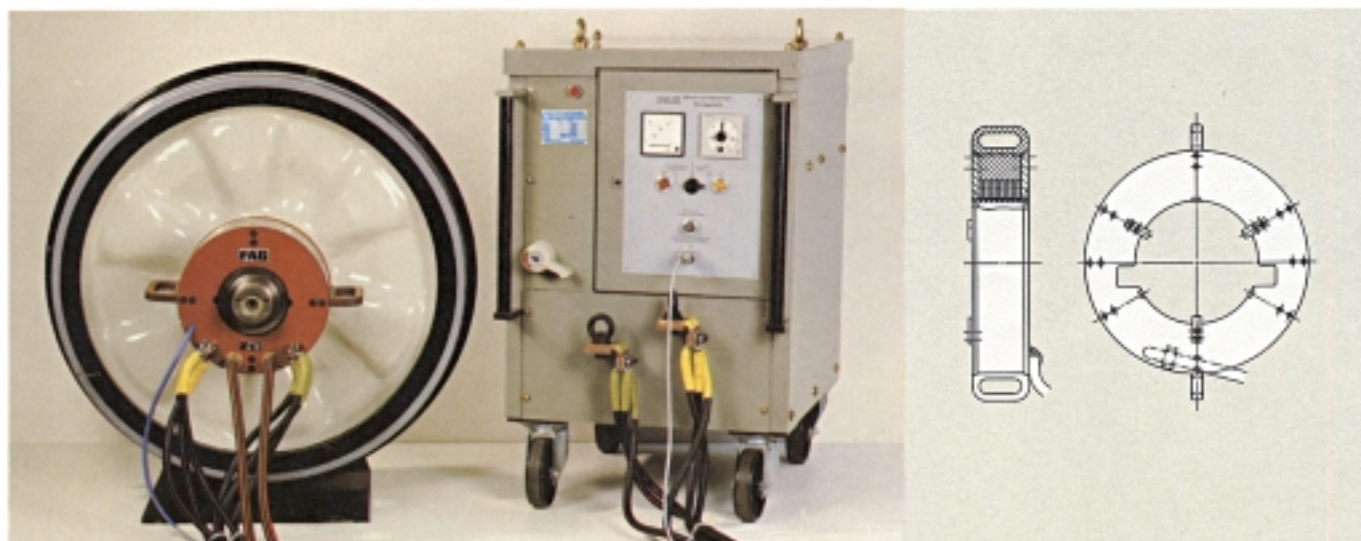



Induction heating device



▽ Dismounting equipment

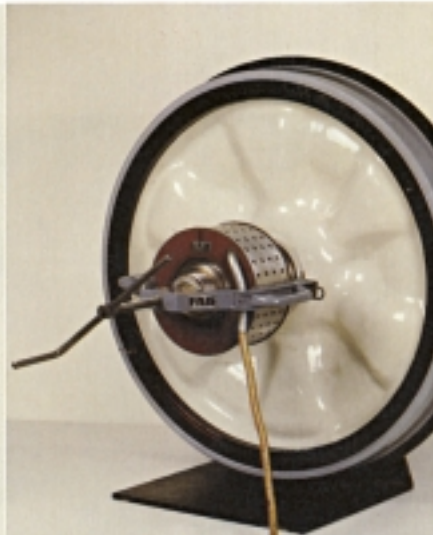
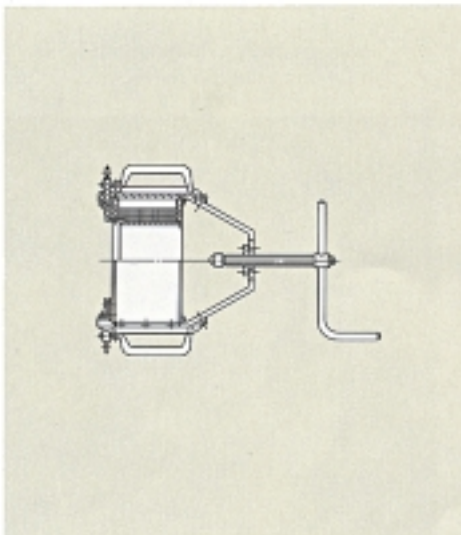

▽ Heating equipment for housing





# FAG research, development and service

FAG research and development activities, long term testing of bearings and lubricants, technical service, customer service

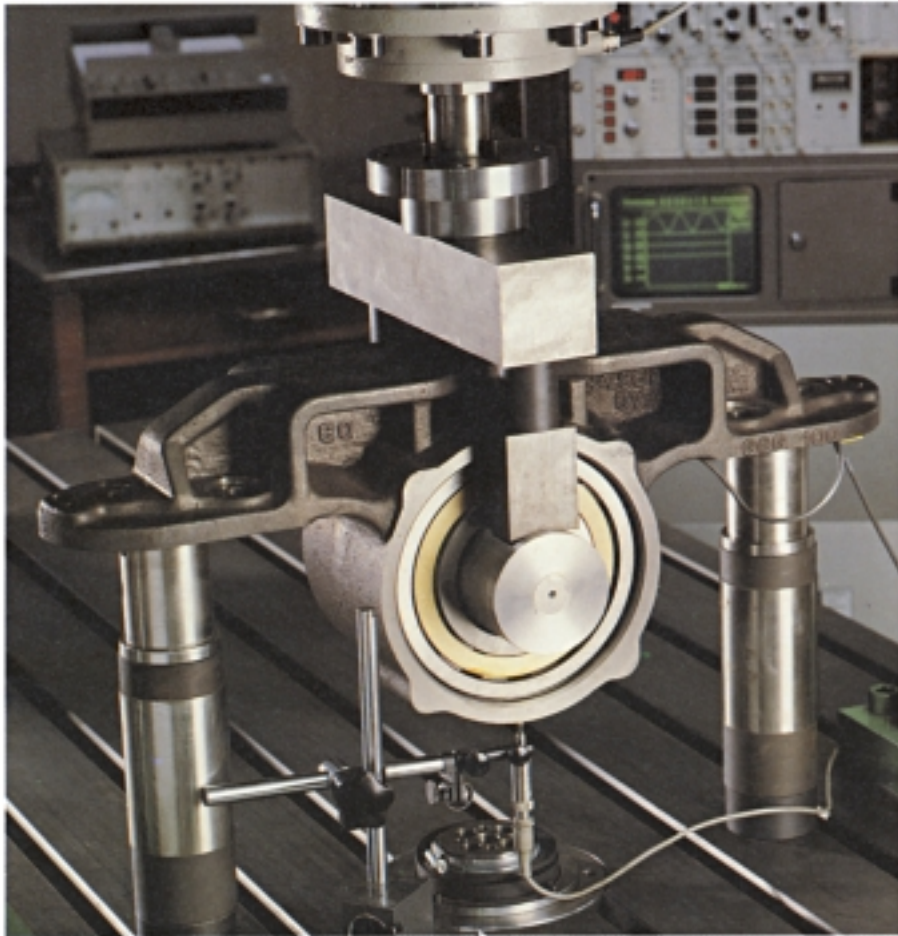

Deformation measurements of an axle box bearing housing made of spheroidal cast iron

Test rigs for long-term testing of rolling bearings



Test rig for axle box bearings



Design of a light metal housing, depending on material



Finite-element structure for calculating an axle box bearing housing

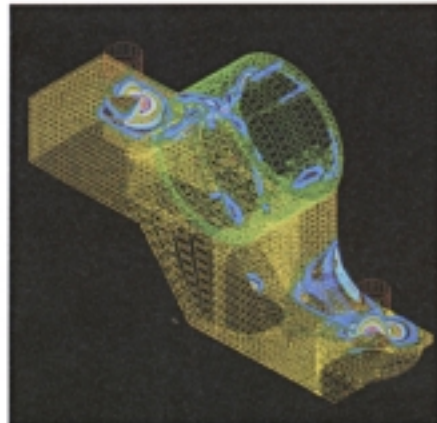

Measuring of stressing by means of strain gauges



Tapered roller bearing unit in the measuring wheelset for the Intercity Experimental (ICE) ▷

▽ Magnetic induction crack inspections



▽ Infrared analysis



▽ Scanning electron microscope and microanalysis

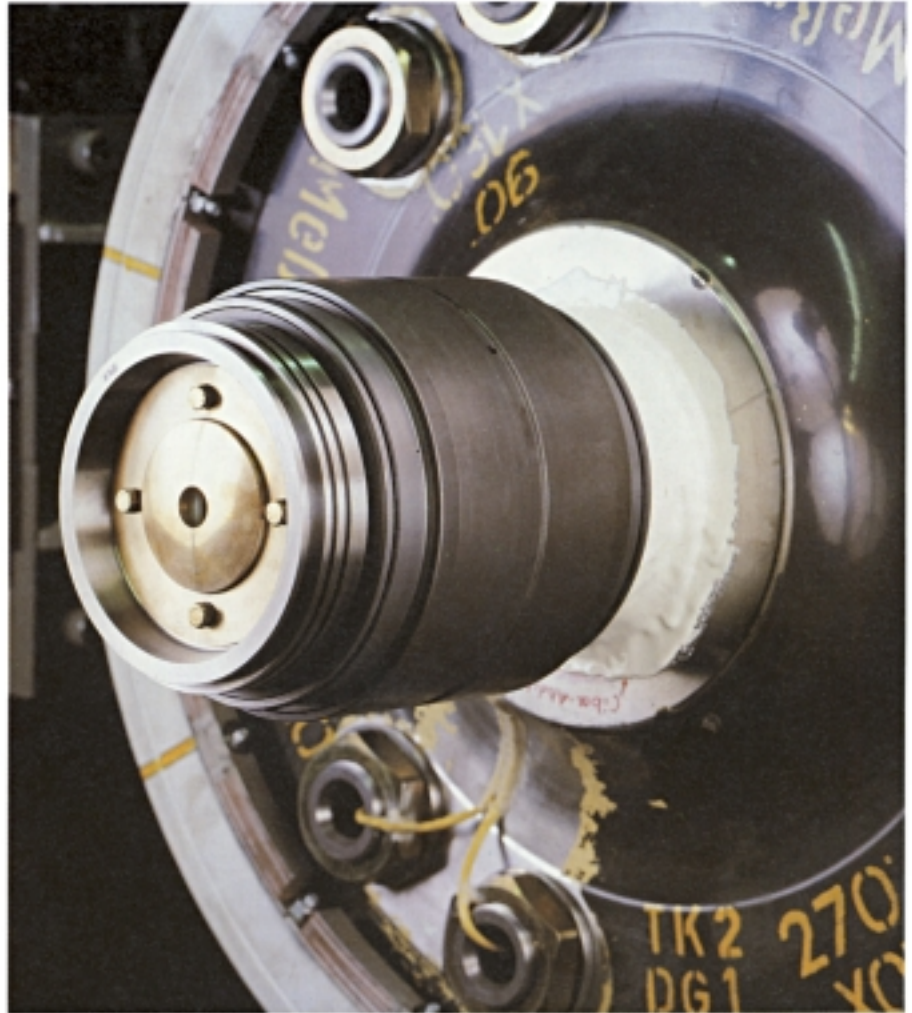

▽ W.A.S. from FAG is a user-friendly complete rolling bearing selection system for IBM-compatible PCs.





## Rail vehicles with FAG rolling bearings



Intercity Express (ICE), German Federal Railways high-speed train  
◀



Interregio rail car ABx791 of the German Federal Railways  
◀



Diesel rail car VT628 for suburban traffic  
◀



Three-phase current locomotive, series 120 of the German Federal Railways ▷



Electric rail car series 420 of the German Federal Railways ▷



Electric locomotive 1044 of the Austrian Railways ▷



## Rail vehicles with FAG rolling bearings



Locomotive with diesel electric drive for New Zealand  
◀



Six-axle articulated rail car of the suburban rail traffic system in Edmonton, Canada  
◀



Passenger car for top cruising speeds ▷



Open freight car ▷



Closed car ▷





## Rail vehicles with FAG rolling bearings



Low-floor wagon  
◁



Double-deck coach in special design for  
transporting vehicles  
◁



Mineral wagon of the Bond Mining  
Company, Liberia  
◁

Flat bogie wagon in special design



Wagon for containers





## Rail vehicles with FAG rolling bearings



Covered high-capacity sash door rail car in special design  
◀



Flat bogie wagon in standard design  
◀



Underground train in Munich  
◀



Tram car in Hanover



Underground train in Berlin



Hamburg Metropolitan Railway



## Rail vehicles with FAG rolling bearings



Underground and suburban train in Athens  
◁



Urban rail car in Stuttgart  
◁

Acknowledgements

BREDA, BRUSH, DB, LHB  
MAN, SGP

---

---

## **FAG Rolling Bearings For Rail Vehicles**

### **Complete Delivery Program**

Every care has been taken to ensure the correctness of the information contained in this publication but no liability can be accepted for any errors or omissions.

We reserve the right to make changes in the interest of technical progress.

**WL 07 150 EA/98.5/8/00**

Printed in Germany by ???